

COSMIC ✦ DEBRIS

USER MANUAL V1.0

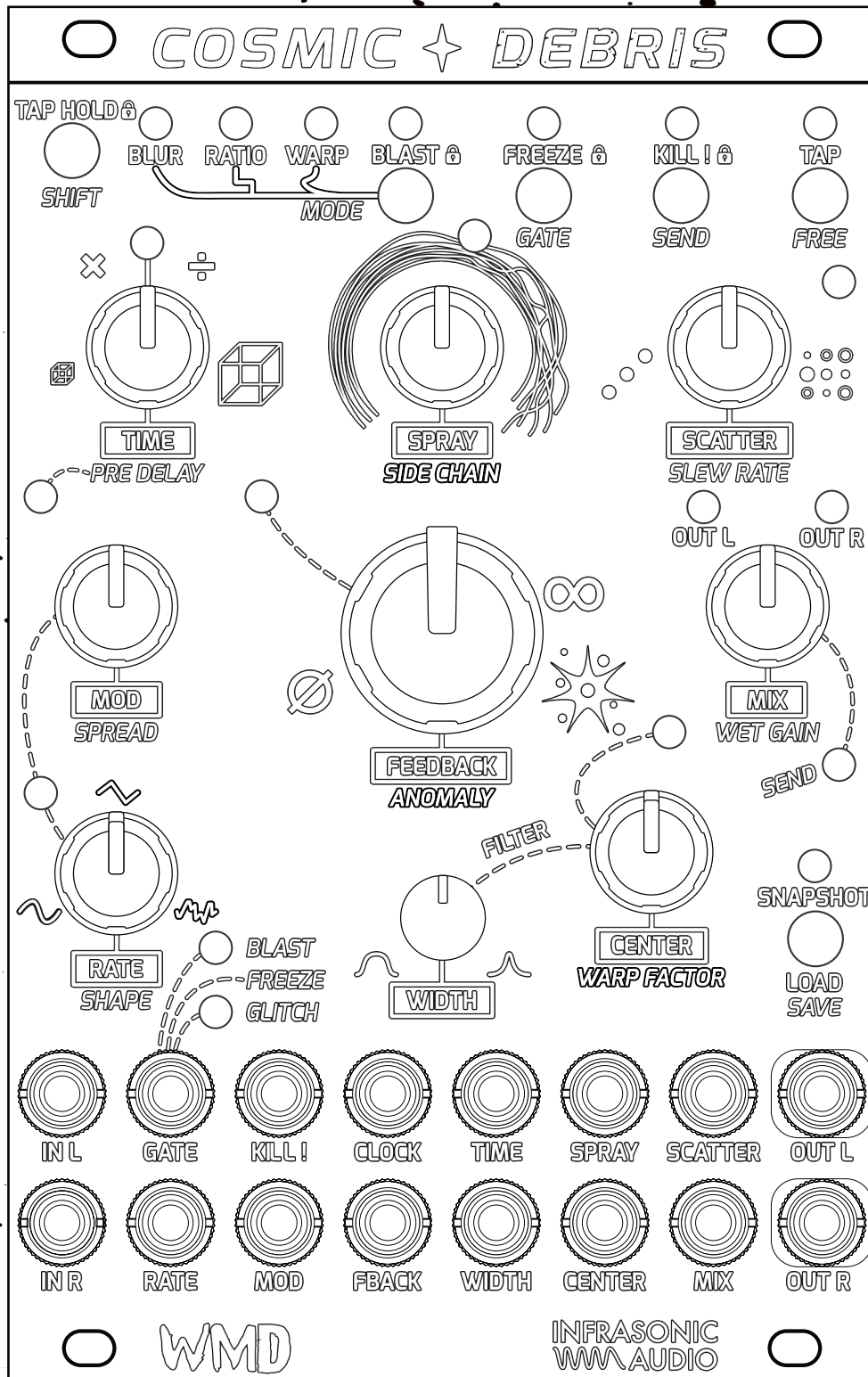

WMD

WMD

INFRASONIC WAVE AUDIO

THEORY OF OPERATION

WHAT IS COSMIC DEBRIS? + DESIGNER NOTES

NOTE FROM THE DESIGNER (NICK DONALDSON)

Cosmic Debris is a very special module for me, the culmination of over 2 years of development effort. From day one, my goals were twofold: 1) to make an amazingly good-sounding reverb effect in Eurorack and 2) to design the interface so that it was fun (and rewarding) to play – not just to set and forget.

The prototyping took me down some deep DSP rabbit holes, and the early prototypes were continuously a part of my own music performance and production; it's a module that I really wanted to make first and foremost because I wanted it to exist, and I hope you will find it equally as inspiring.

The decision to collaborate with WMD has not only made it possible to bring my vision for this module to life but also made it exponentially better than my initial concepts. I'm beyond excited to hear the music you make with it.

WHAT EXACTLY IS COSMIC DEBRIS?

Cosmic Debris is a eurorack module designed with live performance in mind. It's a delay and reverb effect meant to be played and adjusted in real time, like an instrument.

At its core, Cosmic Debris features stereo input and output with a network of 16 individual delay lines, each with inline filtering and multiple feedback routing options.

Three distinct modes provide different sonic territories: tight rhythmic delays, expansive ambient textures, and pitch-shifted shimmers.

It's a true stereo delay effect with features designed for performance, by performers.

Slew limiting on time-based parameters means you can quickly turn a knob and immediately move on to other modules. The delay time continues to shift smoothly in the background, creating sweeping doppler shift effects without requiring constant attention.

The SNAPSHOT function lets you save a reference point. Push the module into chaos for a riser or transition, then snap back instantly—no menu diving, no panic.

The SPRAY parameter morphs delay line lengths in real time. Rhythmic delays dissolve into lush reverb. Dense reverb collapses back into tight, syncopated echoes. Instant delay-to-reverb morphing that responds to your performance.



WMD
INFRASONIC
AUDIO

COSMIC DEBRIS

DELAY AND REVERB PROCESSOR - CONTROLS

SHIFT BUTTON (*SHIFT*):

Hold to enable *SHIFT* functions (labeled with italics) on knobs and buttons. Momentary behavior, so must remain held when using shift functions.

Quickly tap and release, then press and hold *SHIFT* to enable and disable the lock function of *BLAST*, *FREEZE*, and *KILL*.

TIME / PRE DELAY

TIME: Direct control over the length of all delay lines.

- CCW: Faster, shorter delay times, smaller virtual spaces.
- CW: Slower, longer delay times, larger virtual spaces.

TIME CV: Bipolar CV Control over *TIME*. Summed with the knob position and inverted from the knob behavior. Higher voltage = faster time.

PRE DELAY: Adds a delay to the input signal before they reach the delay lines.

***Caution:** *PRE DELAY* delays the input signal, meaning that it will push rhythmic delays off the grid and might not sound great. Recommended for reverb!

***HINT:** When synced to an external clock or tap tempo, *TIME* snaps to different divisions of the clock. Use *SLEW* to

MOD / SPREAD

MOD: Controls the amount of LFO modulating delay time for all 16x delay lines.

SPREAD: Pushes the 16x LFOs out of phase from each other for more textured modulation over the delay lines

- CCW: LFO phase the same on all the delay lines
- CW: LFO phase fully spread out over all the delay lines

RATE / SHAPE

RATE: Controls the speed of the MOD LFO.

SHAPE: Changes the shape of the MOD LFO from Sine, to Triangle, to a smooth random waveform with continuous crossfading between shapes.

GATE INPUT:

- *FREEZE*: Signal high enables *FREEZE*
- *BLAST*: Signal high enables *BLAST*
- *GLITCH*: Signal high forces stuttering via short, pitched buffer loops.

BLAST: Momentary (default) boost to input gain with soft saturation, feedback, and send boost. Behavior can be set to toggle with the lock function.

MODE: Change between *BLUR*, *RATIO*, and *WARP* modes

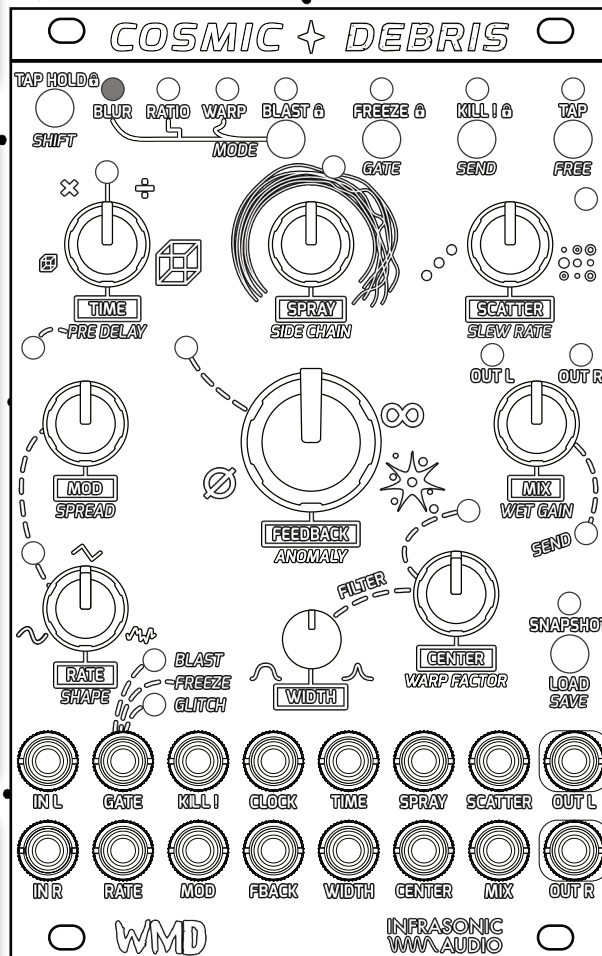

SPRAY: Changes relative lengths of all delay lines in the network.

See *SPRAY* section for more info.

SIDE CHAIN: Ducks the wet signal to the input signal, allowing the input signal to be unaffected and wet signal to come up in level when input is not present.

FEEDBACK: Controls the amount of feedback in the delay network.

- ⊗ : No feedback
- ∞ : Stable 100% feedback with no added gain
- ★ : Adds gain into the feedback network for an explosive growth in feedback.

ANOMALY: Adds bit reduction and pitched buffer stutters into the delay network for a lo-fi, glitchy effect.

KNOB BEHAVIOR: All knobs use soft takeover: the knob position must match the parameter value before changes take effect.

Red flashing LED: Knob position doesn't match. Keep turning until the flashing stops.

LED brightness (when stationary): Shows current parameter value—brighter means higher, dimmer means lower.

FREEZE: Momentarily (default) mutes the input to the delay lines and sets feedback to infinite. Bypasses filters, modulation and pitch shifters (*WARP*) while active.

GATE: Changes the behavior of the *GATE* input jack.

KILL: Clears all delay buffers with a click-less fade. Action on release.

***HINT:** Hold *KILL* and change settings or load snapshot for an instant change to a new setting.

SEND: Enables *SEND* mode. *SEND* led next to mix knob will light red to indicate send mode is active. In send mode, *MIX* becomes send level, allowing for tails to continue after *MIX* knob is turned down.

TAP: Tap Tempo for delay time. An external clock at the *CLOCK* jack will override Tap Tempo

FREE: Disables clock sync turning time into a continuous control. Indicated by slow glowing blue LED above *TAP*

SCATTER: Changes delay feedback routing. CCW: all lines feedback into themselves. CW: Delay lines feed into each other.

See *SIGNAL ROUTING* section below for more info.

SLEW RATE:

CCW: LED is blue, indicating crossfade mode. Changes to *TIME* and *SPRAY* will be crossfaded with no modulation artifacts.

CW: LED is orange and gets brighter the further you turn the knob, indicating a slew is being applied to *TIME* and *SPRAY*. This slows the time it takes to reach a new setting, creating a doppler shift effect along the way for colorful rising or falling transitions.

MIX: Dry/Wet mix for the final outputs stage. Becomes send level in *SEND* mode.

WET GAIN: Direct adjustment of the final level of the summed delay line outputs.

CENTER: Frequency control for 16x variable width bandpass filters placed after each delay line (before feedback paths).

WARP FACTOR: Pitch control for the pitch shifters in *WARP* mode. -1 oct to +1oct range. Knob moves in semitones.

WIDTH: Adjusts the bandwidth of the variable bandpass filter. At 0% *WIDTH* and with *CENTER* at 50%, no audible filtering is applied.

SIGNAL ROUTING

AUDIO INPUTS, OUTPUTS, AND SCATTER MATRIX

Input: Stereo input with left normalised to right. When only the left input is used, the signal is automatically copied to the right input channel.

Output: Stereo output with intelligent routing. When only the left output is used, final output signal (both dry and wet) is summed to mono through the left output jack.

Cosmic Debris features stereo audio input and output. When signals enter the module, the left and right channels are split and routed to the delay lines in an alternating pattern: the left input feeds odd-numbered delay lines (1, 3, 5, 7, etc.) while the right input feeds even-numbered delay lines (2, 4, 6, 8, etc.).

The FEEDBACK and SCATTER controls determine how these delay lines interact with each other. With SCATTER at minimum, each delay line simply feeds back into itself, creating straightforward delay repeats. As you increase SCATTER, the outputs of the delay lines are routed through a matrix that sends them into different delay lines at varying levels. This creates complex interactions between the delays, resulting in evolving, spacious textures and interesting stereo movement.

Finally, the outputs of all delay lines are routed through independent bandpass filters before being recombined and sent to the audio outputs using the same alternating pattern: odd-numbered delay lines sum to the left output, even-numbered delay lines sum to the right output.

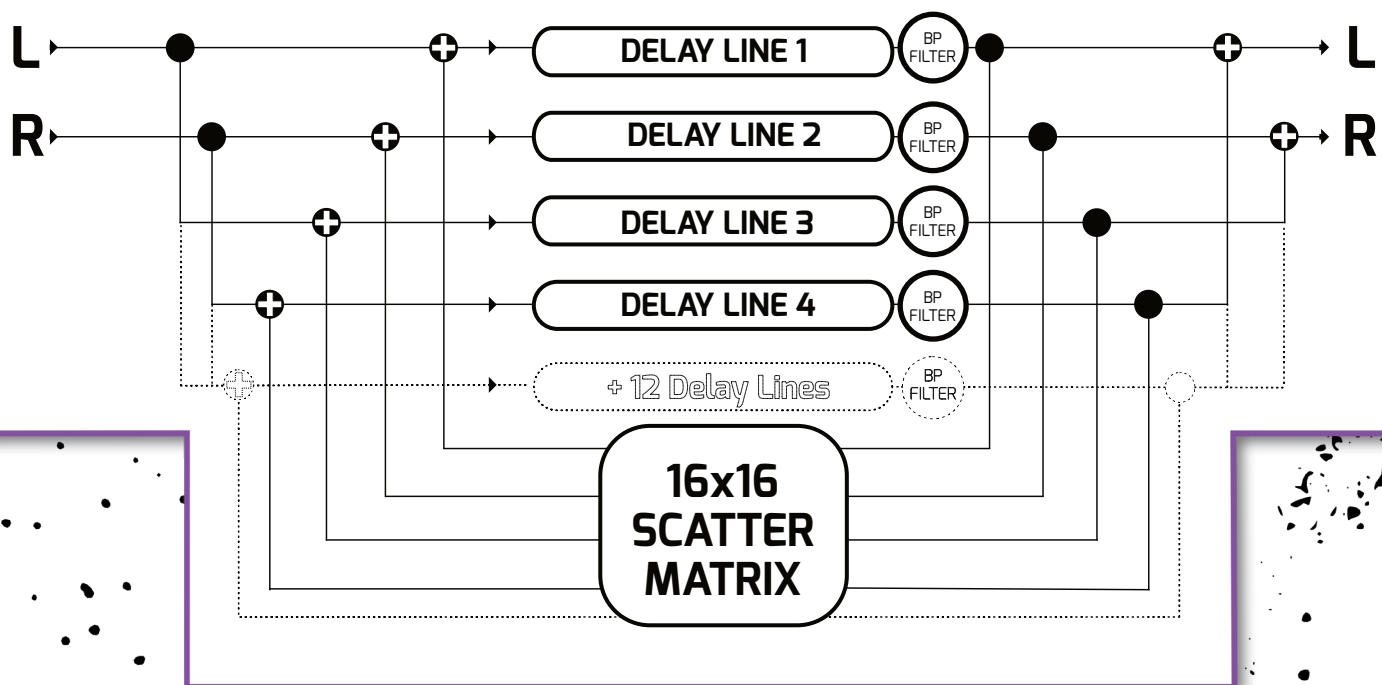

MODES + SPRAY

BLUR, RATIO, WARP

COSMIC DEBRIS has three different modes of operation. These modes mostly address how the **SPRAY** control functions and default settings when **SPRAY** and **SCATTER** are both at 0%. Below is a representation of each mode and how the **SPRAY** control will affect the delay network for different sounds and textures at different positions. Mode selection is saved with **SNAPSHOT** and can be changed while holding **KILL**, so you can cue up a change from one mode to another, while clearing all delay buffers upon release of the **KILL** button.

MODE SELECTION: To switch between modes, hold **SHIFT** and press **MODE**.

BLUR: With **Spray** at 0%, all 16 delay lines are the same length.

Turning **SPRAY** clockwise (CW) shortens all delay lines but the first, which remains at the current **TIME** setting. All of the delay lines become different lengths. With faster delay times, **SPRAY** will go from a traditional delay to a lush reverb very quickly. Add some **MOD** to add chorusing to the delays and make the reverb much more 'Cosmic'.

SPRAY AMOUNT

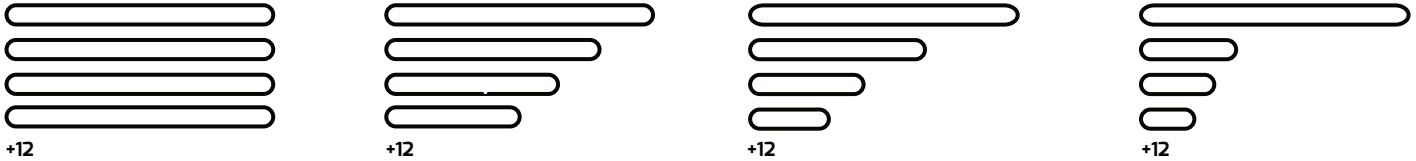

RATIO: With **Spray** at 0%, every other delay line is 2x longer. This creates a nice delay with lots of stereo movement at the minimum settings.

Turning up **SPRAY** will spread the delay times out to different lengths that are locked into musical ratios of the master delay time or clock setting. With slower **TIME** settings, **SPRAY** will increase the rhythmic pitter patter created in the stereo settings and add jittery stutters. As the time is sped up, these delay lines become shorter and more staccato until they are unintelligible and sound similar to reverb, with a bit more of a tin-can or static sound.

SPRAY AMOUNT

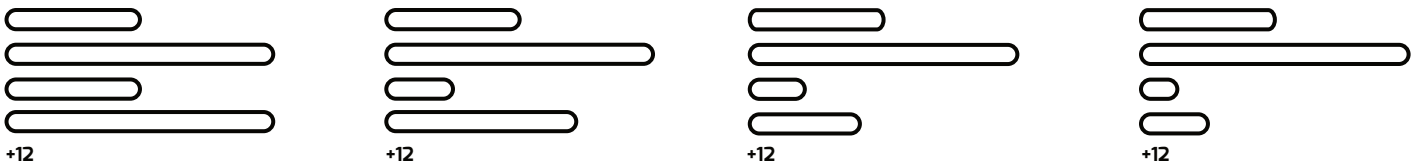

WARP:

Warp mode is set up very similar to BLUR mode, however, there are pitch shifters placed in the feedback loop of the first two delay lines. **WARP FACTOR** adjusts the interval for the pitch-shifters. **WARP FACTOR** is quantized to semi-tones and has a range from -1 Octave to +1 Octave. When the knob is set to 50%, the pitch shifters are off.

At 0% spray, the input signal is fed only into the first two lines, with increased signal level to maintain relatively consistent volume at the final mix out output. As **SPRAY** is turned from 0% to 50%, the input signal is fed into all the other lines (as per BLUR) with gradual crossfade, i.e. the input into the first two is attenuated and the input into all the others is amplified. At 50% and above, the input is fed equally to all lines.

SPRAY AMOUNT

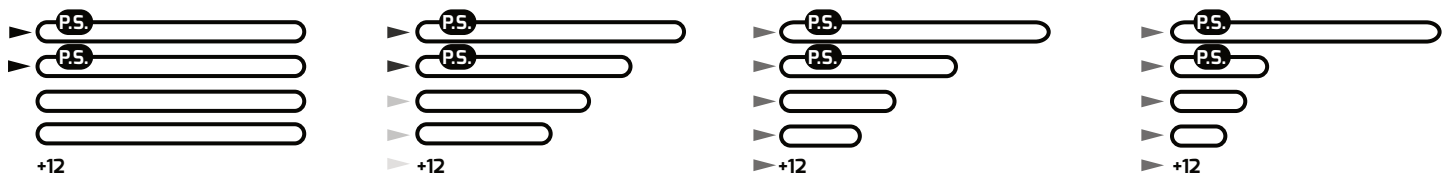

PATCH NOTES

KARPLUS-STRONG = PHYSICAL MODELING



KARPLUS-STRONG

With incredibly fast delay times below 1ms, Cosmic Debris can create stunning physical modeling and Karplus-Strong effects. Use a short, plucky sound with a fast envelope as your input, then start with these settings and experiment with the parameters to make them your own. Explore what happens in different modes and when you introduce MOD/SPREAD, filtering, and SPRAY.

INSTRUCTIONS

Match the knob positions shown in the diagram on the right. Leave CLOCK unpatched and press SHIFT + TAP to ensure the module is in FREE time mode, not tracking a clock.

Feed a percussive pluck or even a raw trigger signal into Cosmic Debris' input.

Karplus-Strong synthesis is all about the resonance of the delay itself, so shorter input sounds work best.

Patch 1V/oct information into the TIME input to sequence the pitch of the delay.

Use the default MIX mode (not send mode) to achieve a 100% wet signal.

Set all SHIFT controls to their default positions (fully counter-clockwise) except SLEW RATE which should be set to the fastest slew time for best results, i.e. the lowest setting before the LED turns blue indicating crossfade mode.

Use FEEDBACK to control the decay time of the plucked string sound.

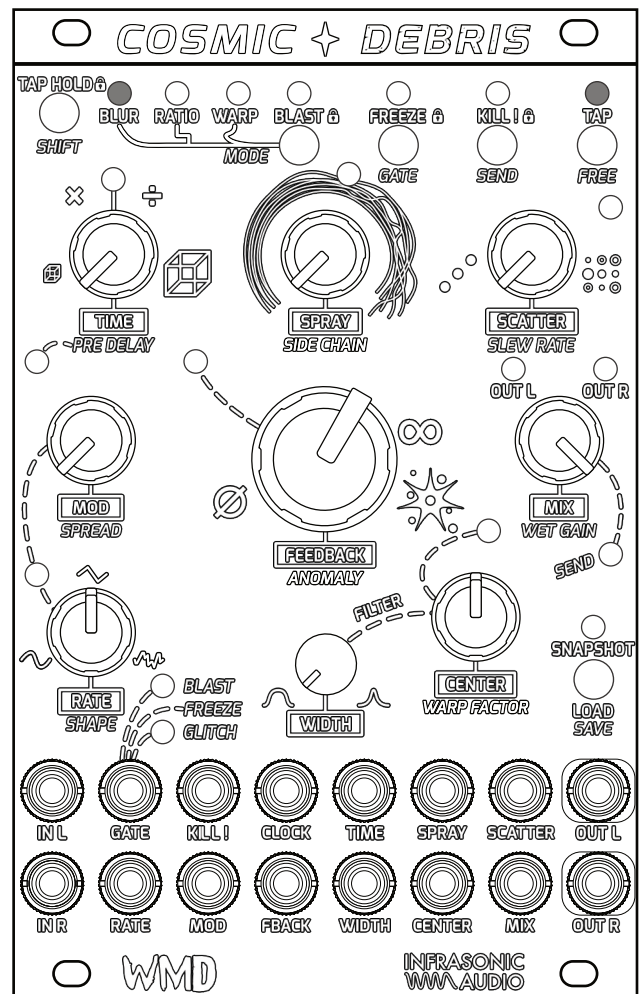

HINT:

The settings above will produce a classic Karplus-Strong sound—often described as physical modeling of a plucked string. You can play this "string" melodically by patching a 1V/oct signal into the TIME jack to sequence different pitches.

When the TIME knob is fully clockwise and the TIME jack receives 0V (or left unpatched), the delay time is tuned to 130.8 Hz (C3). Use this as your tuning reference to keep your patches in key.

To move beyond string synthesis and explore metallic, sheet-metal-like tones, increase SPRAY and add subtle MOD with SPREAD. Also try using RATIO mode instead of BLUR for different harmonic content.

PATCH NOTES

AMBIENT REVERB + SHIMMER VERB

COSMIC DEBRIS can morph from a traditional delay into a lush reverb in seconds. In **BLUR** and **WARP** modes, the **SPRAY** control will wash out the sound into an ambient field of reverb. **RATIO** mode is worth experimenting with as well for more staccato sounds with slower **TIME** settings until they become unintelligible and sound similar to reverb, with a bit more of a tin-can or static sound.

INSTRUCTIONS

Match the knob positions shown in the diagram on the right, using **BLUR** mode at first. Switch to **WARP** and set **WARP FACTOR** at 100% for octave up shimmers!

Start with percussive sounds at the input to dial in the reverb character. Once you've found your sound, introduce slower, more sustained material and let it bloom in the beautiful space you've created.

No external CV is required for this patch, but here are some things to try:

- CV into **CENTER**
- Triggers into **KILL**
- Gates into the gate input (set to **BLAST** mode)

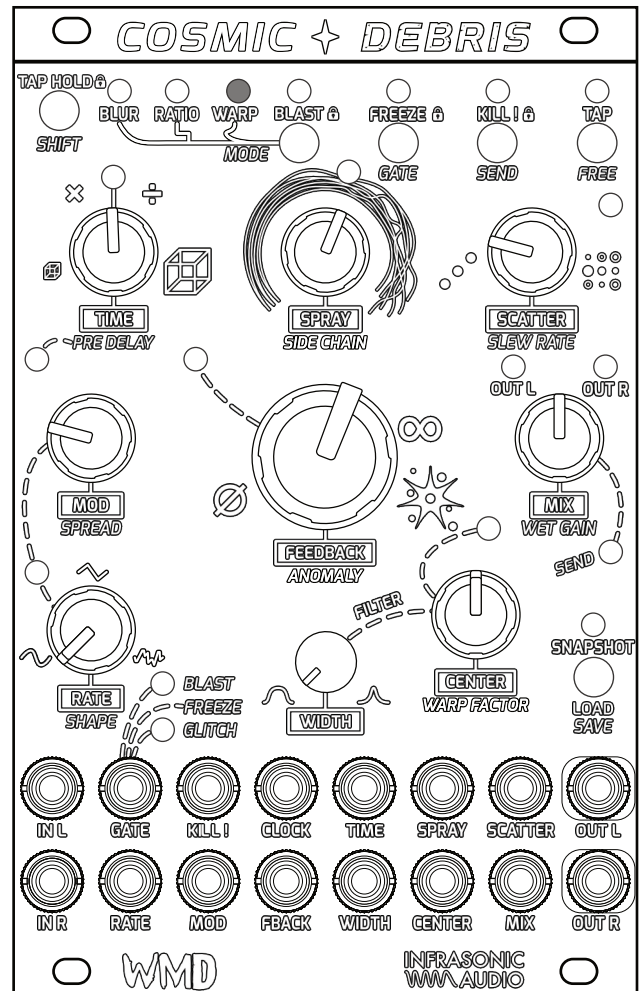

Routing tips:

If using **Cosmic Debris** in an effects loop, keep **MIX** at 100% in default mode. If using it as an insert or inline with your synth voice, try **SEND** mode! This pushes your signal level into the effect and preserves tails when you turn the send level down.

Experiment with **PRE DELAY** and **SIDE CHAIN** to keep the reverb out of the way of your input signal, allowing it to bloom when the input fades away.

Try **BLAST** for momentary boosts into the effect and **FREEZE** to hold a sound into infinity.

PATCH NOTES

RHYTHMIC STEREO DELAYS

Who doesn't love rhythmic pitter-patter? This patch delivers exactly that. Use an external clock or TAP in a tempo for sync'd delay repeats and short loops that add syncopated rhythms and musical textures to your patch. Increase SCATTER to send delays bouncing between each other, creating playful, evolving interactions across the stereo field.

INSTRUCTIONS

Start with percussive sounds at the input to dial in the delay character and hear the difference between modes and SCATTER settings.

Feed a clock signal into the external input or use the TAP button to tap in a tempo in time with your song.

Set TIME somewhere between 12 and 3 o'clock for the most rhythmic syncopations.

Match the knob positions shown in the diagram on the right, starting with BLUR mode for the most traditional delay sounds. Then experiment with RATIO and WARP modes for different rhythmic patterns and pitch-shifting effects!

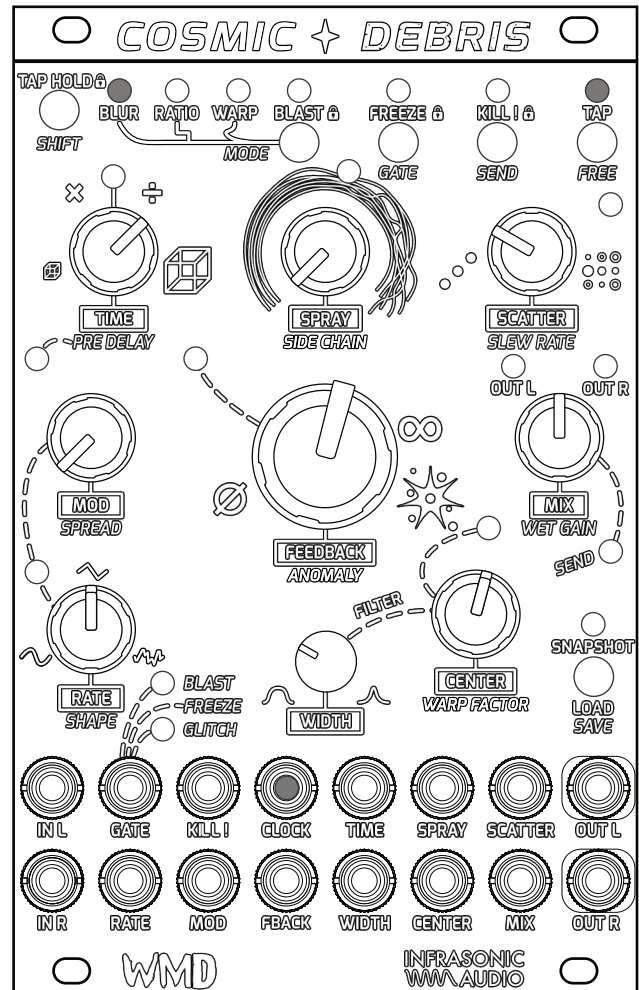

TIPS:

Try different *SLEW* positions and adjust the TIME and SPRAY controls to get a feel for how they interact at various slew settings.

Introduce ANOMALY and send gates into the GATE input (set to GLITCH) for lo-fi degradation, stutter, and glitch effects.

If things ever get out of hand, remember you can always tap the KILL button to clear the delay buffers and start fresh.

PATCH NOTES

"REESE BASS"

SUPER SAW / "REESE BASS" PROCESSOR

A variation on Karplus-Strong synthesis, this patch transforms a simple saw wave into a massive, rave-ready super saw. Fast TIME settings, short FEEDBACK, along with MOD and SPREAD create quick copies of the incoming waveform, simulating multiple stacked oscillators in unison. Patch 1V/oct into the RATE CV input and the modulation rate will track each note, just like a classic Reese bass.

Using BLUR mode, match the knob positions shown in the diagram on the right. Leave CLOCK unpatched and press SHIFT + TAP to ensure the module is in FREE time mode, not tracking a clock.

Match the settings on the diagram to the right.

Adjust the SPREAD control between 25% and 75%, and tune to taste. This is where you can dial in how many "copies" of the waveform there will be. Adjust mod to set the amount of "detune".

Patch the same 1V/oct signal that is controlling your oscillator into the RATE CV input. Now, the modulation will be faster with higher notes, and slower with lower notes.

Remember to keep the filter WIDTH at its widest setting with CENTER set to 50% in order to preserve as many harmonics as possible.

Keep MIX at 50% in the default mix mode, but also try increasing it to 50% more a more dramatic effect.

Try a mono input and a stereo output and start to play with SPRAY and SCATTER ever so subtly for some strange artifacts.

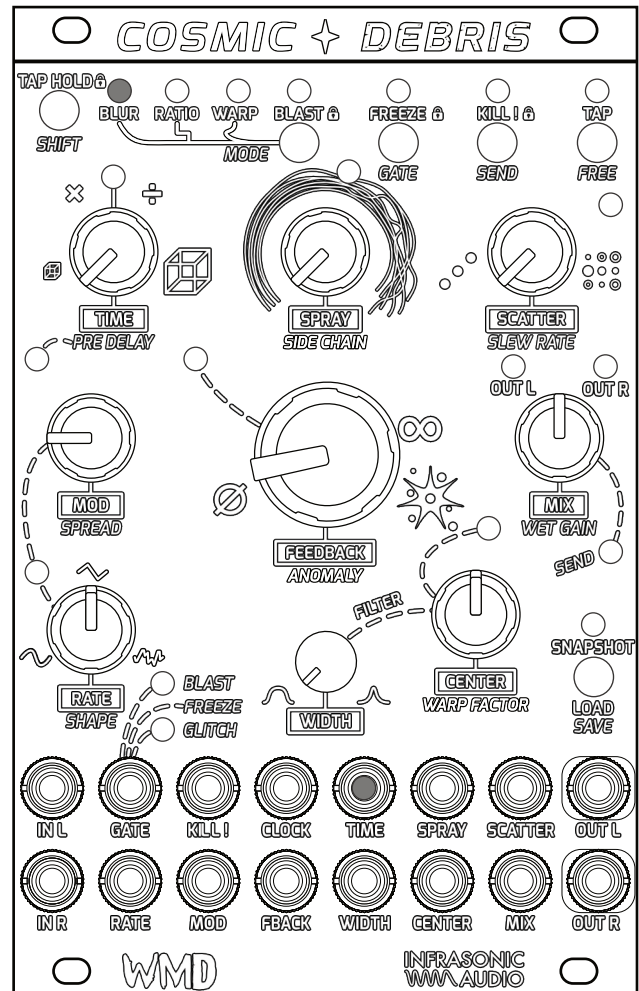

TIPS:

Classic "Reese Bass" sounds were created by sampling a sound with modulation. When the sample was pitched up and down, the modulation was also affected. This was likely an unintentional artifact that became an easily recognizable attribute to the sound. With this patch, we create the same effect with synthesis!

Use a filter and VCA after Cosmic Debris to further tune the timber and make it rhythmic.

TECH SPECS

MANUAL CONVENTIONS, SPECS, POWER

CONVENTIONS IN THIS MANUAL:

KNOBS, BUTTONS, JACKS are all labeled in explanations in all capitals. Example: TIME.

SHIFT PARAMETERS are all labeled in explanations in all capitals and in *italic* font.

CCW / CW are terms used for “clockwise” and “counter clockwise” knob positions and rotations.

0% / 100% are terms for when knob positions are fully CW or CCW.

***HINT** is a bit of extra information we find helpful with troubleshooting.

***CAUTION** is a reminder of a that a function may cause Cosmic Debris to behave in a way you don't expect right away. Again, just notes for troubleshooting.

Specs:

Size: 16 HP

Depth: 32mm (with cables)

Power: +130mA, -8mA

CV/Gate Inputs:

CV and Gate Inputs are 100kΩ impedance

CV inputs are -5V to +5V

Gate inputs are 2V threshold Schmitt Trigger

Audio Input/Output:

Input Impedance: 50kΩ AC Coupled, 0.3Hz HPF

Input Voltage Range: 21.8 Volts Peak-to-Peak

Output Impedance: 1kΩ DC Coupled

Output Voltage Range: 22 Volts Peak-to-Peak

I/O: 24 bit/48kHz

Internal Audio 32 bit float math

Minimum delay time: 400μs

Throughput Latency: 1.5ms

POWER: Cosmic Debris features a shrouded, keyed power header to prevent power cables being plugged backwards and also is protected against reverse polarity. In the event a cable is plugged in backwards, no damage will be done, however, the module will not power up.

Plug in a 16 to 10 pin ribbon cable connected to your power supply's bus board into the module with the red strip toward the white line on the rear pcb. Secure the module to your case's rails with the included screws and you are good to go!

RED STRIPE
TOWARD -12V

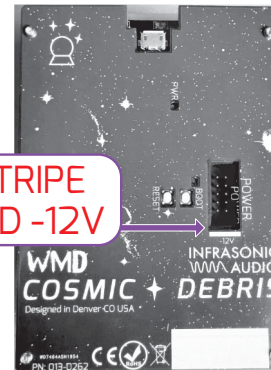

USB INPUT: Used for initial programming (at the factory) and software issues in the field.

FIRMWARE UPDATES: Upon release, Cosmic Debris is considered finished. No future updates expected.

In the event any bugs are discovered we will distribute an update via WMDevices.com. Instructions will be included with the update file.

BOOT TIME: Cosmic Debris has a boot time of up to 3 seconds built into the hardware. This is to ensure the power source is stable before the module powers up.

WMD
INFRASONIC
WWW.AUDIO